



Indoor Voltage Transformer

**Models PTG4T-1-75
PTG4T-2-75 rev 53023**

ACCURACY CLASS:

0.3 WXY, 1.2Z at 100% rated voltage with 120V based ANSI burden.
0.3 WXY, 1.2Z at 58% rated voltage with 69.3V based ANSI burden.

FREQUENCY:

60 Hz.

MAXIMUM SYSTEM VOLTAGE:

12 kV, BIL 75kV full wave

THERMAL RATING:

1000 va AT 30°C amb.

750 VA at 55°C. amb.

APPROXIMATE WEIGHT:

60 lbs., unfused

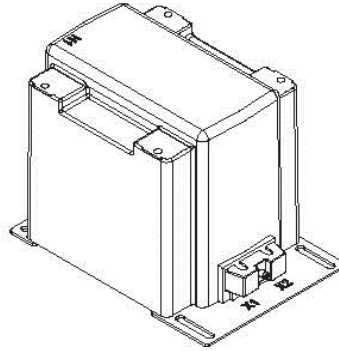

CERTIFICATIONS:



- Primary terminals that are unfused are 1/4-20 brass screws with one lockwasher and flat washer.
- Primary terminals that are fused are 1/4-20 brass screws with one flat washer, lockwasher and two nuts.
- Secondary terminals are No. 10-32 brass screws with one flat washer and lockwasher.
- The transformers are tested for partial discharge to Canadian Standards CAN 3-C13-M83. This test can also be carried out to IEC requirements if requested.
- The core and coil assembly is vacuum encapsulated in polyurethane resin.
- Thermal burden rating is for 120 volt secondaries
- Plated steel mounting base.
- Fuses have 0.81" Dia Caps and 9.5" clip centers.
- Switchgear style is similar to fused style. No fuse or fuse clip is provided, but inserts for fuse clips are supplied.
- A test cord is provided with each unit.

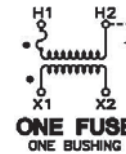
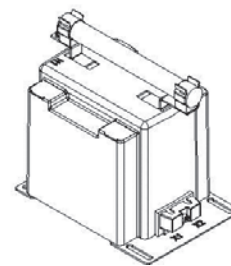
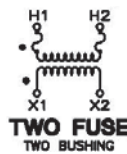
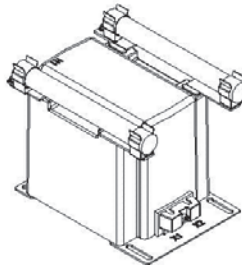
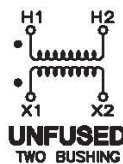
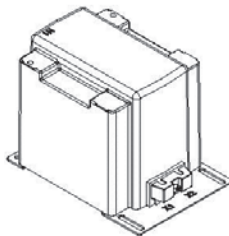

ONE BUSHING(b)					CATALOG NUMBERS		
GROUP	PRIMARY VOLTAGE	RATIO	SECONDARY VOLTAGE	R FR (c)	FUSES	FUSE CLIPS ONLY	SWITCHGEAR STYLE
4A	4200	35:1	120	65	PTG4T-1-75-422F	PTG4T-1-75-422C	PTG4T-1-75-422S
4A	4800	40:1	120	65	PTG4T-1-75-482F	PTG4T-1-75-482C	PTG4T-1-75-482S
4B	6600	60:1	110-50Hz	65	PTG4T-1-75-662F	PTG4T-1-75-662C	PTG4T-1-75-662S
4B	7200	60:1	120	65	PTG4T-1-75-722F	PTG4T-1-75-722C	PTG4T-1-75-722S
4B	8400	70:1	120	65	PTG4T-1-75-842F	PTG4T-1-75-842C	PTG4T-1-75-842S
4B	11000	100:1	110-50Hz	65	PTG4T-1-75-113F	PTG4T-1-75-113C	PTG4T-1-75-113S
4B	12000	100:1	120	65	PTG4T-1-75-123F	PTG4T-1-75-123C	PTG4T-1-75-123S

TWO BUSHING(a)				CATALOG			
GROUP	PRIMARY VOLTAGE	RATIO	SECONDARY VOLTAGE	UNFUSED	FUSES	FUSE CLIPS ONLY	SWITCHGEAR STYLE
1	4200	35:1	120	PTG4T-2-75-422	PTG4T-2-75-422FF	PTG4T-2-75-422CC	PTG4T-2-75-422SS
1	4800	40:1	120	PTG4T-2-75-482	PTG4T-2-75-482FF	PTG4T-2-75-482CC	PTG4T-2-75-482SS
2	6600	60:1	110-50Hz	PTG4T-2-75-662	PTG4T-2-75-662FF	PTG4T-2-75-662CC	PTG4T-2-75-662SS
2	7200	60:1	120	PTG4T-2-75-722	PTG4T-2-75-722FF	PTG4T-2-75-722CC	PTG4T-2-75-722SS
2	8400	70:1	120	PTG4T-2-75-842	PTG4T-2-75-842FF	PTG4T-2-75-842CC	PTG4T-2-75-842SS
2	11000	100:1	110-50Hz	PTG4T-2-75-113	PTG4T-2-75-113FF	PTG4T-2-75-113CC	PTG4T-2-75-113SS
2	12000	100:1	120	PTG4T-2-75-123	PTG4T-2-75-123FF	PTG4T-2-75-123CC	PTG4T-2-75-123SS

Products are manufactured in a plant whose quality management system has been certified to be in compliance with ISO 9001:2015 by NQA

- (a) Two fuse transformers should not be used for Y connections. It is preferred practice to connect one lead from each voltage transformer directly to the neutral terminal using a fuse in the line side of the primary only. By using this connection, a transformer can never be made "live" from the line side by reason of a blown fuse in the neutral side. For continuous operation, the transformer primary voltage should not exceed 110% of rated value.
- (b) Voltage transformers connected line-to-ground cannot be considered to be grounding transformers and must not be operated with the secondaries in closed delta because excessive currents may flow in the delta.
- (c) Possibility of ferroresonance should be considered.

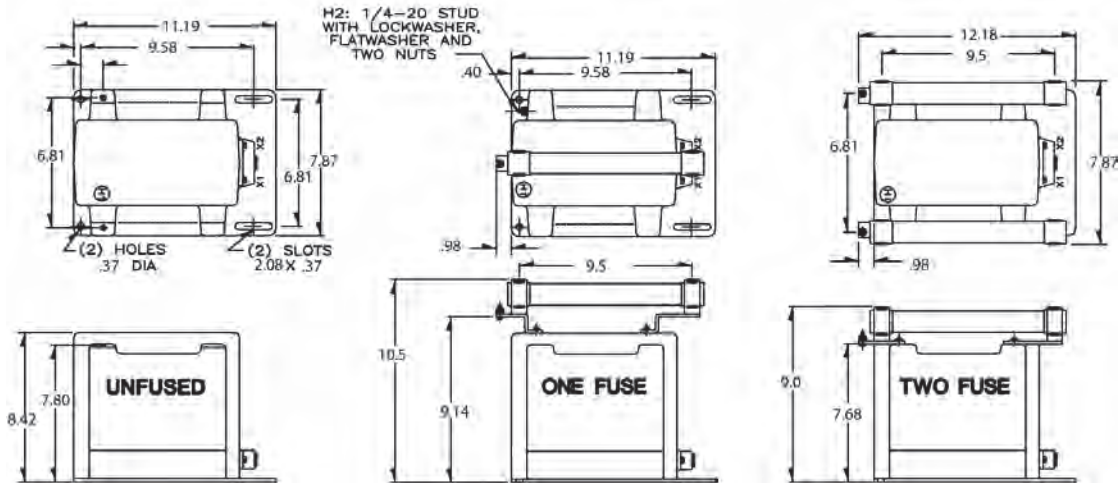

Recommended spacing is for guidance only. User needs to set appropriate values to assure performance for: high potential test; impulse test; high humidity; partial discharge, high altitude; and other considerations like configuration.

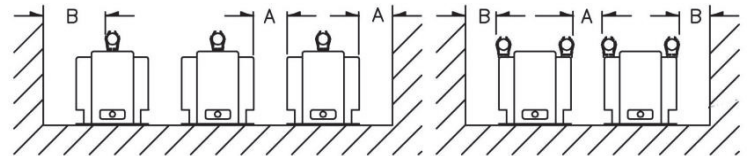

FUSE FOR MODEL PTG4 TRANSFORMER	RATING VOLTS	INTERRUPTING AMPERES (SYM)	SUGGESTED RATING * CONTINUOUS AMPERES	CAP DIA. INCHES	LENGTH INCHES	CLIP CENTERS INCHES
4200:120V	12 kV	50,000	2.0E	0.812	10	9.5
4800:120V	12 kV	50,000	2.0E	0.812	10	9.5
6600:110V	12 kV	50,000	1.0E	0.812	10	9.5
7200:120V	12 kV	50,000	1.0E	0.812	10	9.5
8400:120V	12 kV	50,000	1.0E	0.812	10	9.5
11000:110V	12 kV	50,000	0.5E	0.812	10	9.5
12000:120V	12 kV	50,000	0.5E	0.812	10	9.5

The circle diagram can be used to predict the performance of a transformer for various loads and power factors. A convenient scale of volt-amperes is shown on the unity power factor line (u.p.f.) and commences at the zero or no-load locus. To use the diagram, measure the known V.A. and scribe an arc about the "zero" locus of a length that contains the angle of the burden power factor. The point at which the arc terminates is the error locus in phase angle minutes and ratio correction factor.

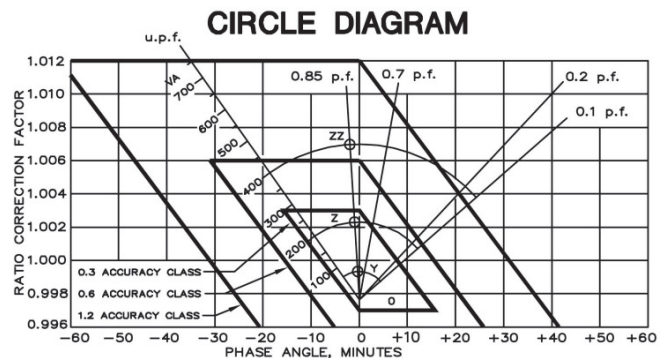

Products are manufactured in a plant whose quality management system has been certified to be in compliance with ISO 9001:2015 by NQA