



Current Transformer

Model 8SHT-0.333

CERTIFICATIONS:



8SHT-0.333



APPLICATION:

Metering

FREQUENCY:

50-400 Hz.

INSULATION LEVEL:

600 Volts. 10 kV BIL. full wave

WINDOW DIAMETER:

3.25"

APPROXIMATE WEIGHT:

2.5 lbs.

CONNECTIONS:

- Flexible Leads are UL 1015 105°C, CSA approved #16 AWG, 24" long
- Non-standard length to be specified
- Terminals are brass studs No. 8-32 UNC with one flat washer, lockwasher, and regular nut
- Mounting kit 59-0220

Model	8SHT-0.333
Window Size	3.25
Width	5.73
Height	5.73
Depth	1.15

MODEL 8SHT
Window Diameter 3.25"
Approximate weight: 2.5 lbs.

CATALOG NUMBER	CURRENT VOLTAGE RATIO
8SHT-201-0.333	200:0.333
8SHT-251-0.333	250:0.333
8SHT-301-0.333	300:0.333
8SHT-401-0.333	400:0.333
8SHT-501-0.333	500:0.333
8SHT-601-0.333	600:0.333
8SHT-751-0.333	750:0.333
8SHT-801-0.333	800:0.333
8SHT-102-0.333	1000:0.333
8SHT-122-0.333	1200:0.333
8SHT-152-0.333	1500:0.333
8SHT-162-0.333	1600:0.333
8SHT-202-0.333	2000:0.333
8SHT-252-0.333	2500:0.333
8SHT-302-0.333	3000:0.333
8SHT-322-0.333	3200:0.333

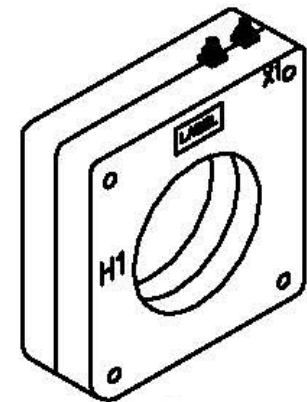
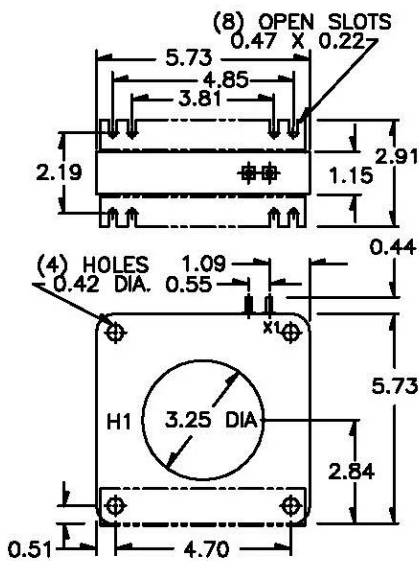

8SHT-0.333

Products are manufactured in a plant whose quality management system has been certified to be in compliance with ISO 9001:2015 by NQA