

Before installing the VMX2 Compact Soft Starter thoroughly read the user manual included with this product on the CD or download the VMX2 user manual from www.motortronics.com (Mobile device friendly).

After all electrical connections have been made; apply power to the VMX2 soft starter. The display on the Digital Keypad should be reading [0000.]

IMPORTANT!

To operate the VMX2 soft starter the motor full load amps parameter F001 has to be programmed.

Motor Full Load Amps (FLA) can be found on the motor name plate.

F001 Programming Example: Shows how to enter motor full load amps nameplate data into parameter F001 (48A).



**MOTOR FLA (F001)
must be programmed
for unit to operate!**

Press Key...	Display Shows...	Means...
	0000.	Phase A Current
Fn	F001	Function #1 Selected
READ ENTER	0000	Previous Setting of Function #1
↑	0008	New Value of First Digit
←	0008	Cursor (flashing) Position Shift
↑	0048	New Value of Second Digit
READ ENTER	End	Value Accepted (flashes once)
	F001	Return to Function # Display

Two Wire Control: Relay / PLC Connection

Connect a dry (voltage free) maintained contact closure between terminals 1 and 3 as shown below. When this contact is closed, the VMX2 Series starter will start and run. When it is opened, it is the same as a Stop command.

Note: It is advisable to set the overload relay to the manual reset position. Verify FN005 = 0. This will prevent the motor from restarting if the thermal overload trips and then cools off.

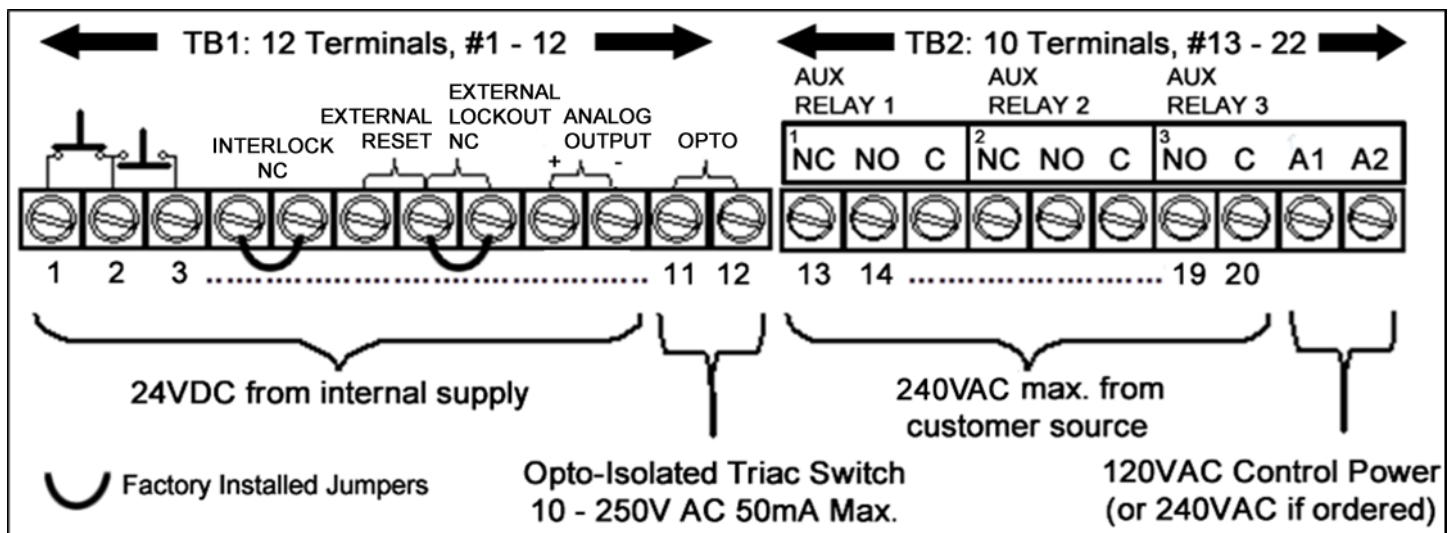

Start-up Parameters and Factory Defaults

Fn #	Function Name	Factory Setting	Description / Factory Setting
F001	Motor Nameplate FLA.	0	FLA must be programmed for the starter to operate.
F002	Motor Nameplate Service Factor	1.0 SF	Change only if necessary and for motors rated above 1.0SF
F003	Overload Class During Start	Class 10	NEMA / UL Class 10
F004	Overload Class During Run	Class 10	NEMA / UL Class 10
F005	Overload Reset	0 (Manual)	0 = Manual
F010	Ramp Profile	1	Ramp 1 and Ramp 2 = Voltage Ramp with Current Limit
F011	Initial Torque	60%	60% Initial Voltage
F013	Ramp Time	10 sec	10 Second Ramp (Ramp 1)
F014	Current Limit	350%	350% of programmed FLA
F015 – F018	Ramp 2 settings	---	Inactive unless Ramp 2 Input is closed
F019 – F050	Software protection and control features	---	Inactive unless selected
F051	nCP Trip (No Control Power)	0	Disabled
F052	Auto reset selected faults	4	Phase loss only
F053	Auto reset attempts	0	Disabled
F054 – F059	Timer and counter value readouts	---	Read only
F060	Aux Relay #1	1	Run / Stop
F061	Aux Relay #2	2	At-Speed / Stop
F062	Aux Relay #3	22	Any Trip
F063	Aux Relay Delay	0	No Delay
F065 – F068	Communications	---	See VMX2 User Manual for set-up
F070	Parameter Lock	0	User password disabled
F071	Reset Function	0	Use to reset to default values
F073 – F080	System settings and time clock	---	User choice to adjust clock
F085 – F093	Fault History	---	Read only
F094 – F097	Run Time / Start cycle history	---	Read only
F098 – F101	Phase Loss / Rotation settings	---	See VMX2 User Manual for set-up
F102 – F107	kW / P.F. trip settings	---	See VMX2 User Manual for set-up
F108 – F110	Analog Output set-up	---	See VMX2 User Manual for set-up
F111	default display setting	---	See VMX2 User Manual for set-up
F113	Alternate functions for Ramp2/Jog inputs	---	See VMX2 User Manual for set-up

Fault Codes: Refer to the Fault Code List table 7.1 in the VMX2 user manual

California Customers:

California Proposition 65 Warning

WARNING: this product and associated accessories may contain chemicals known to the State of California to cause cancer, birth defects, or other reproductive harm. For more information visit <https://p65warnings.ca.gov>